

SECTION (1:25)

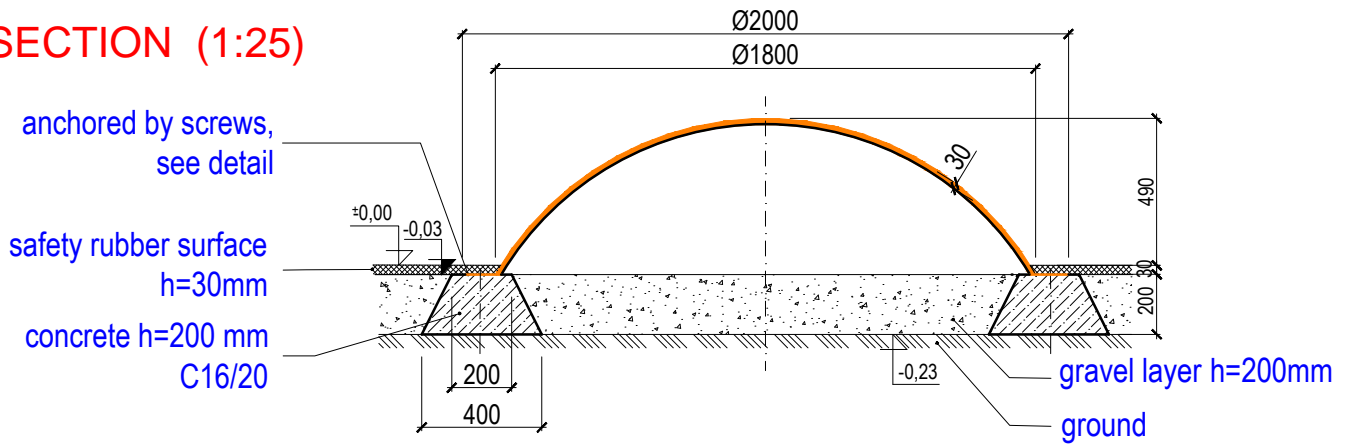

FOUNDATION GROUND PLAN (1:25)

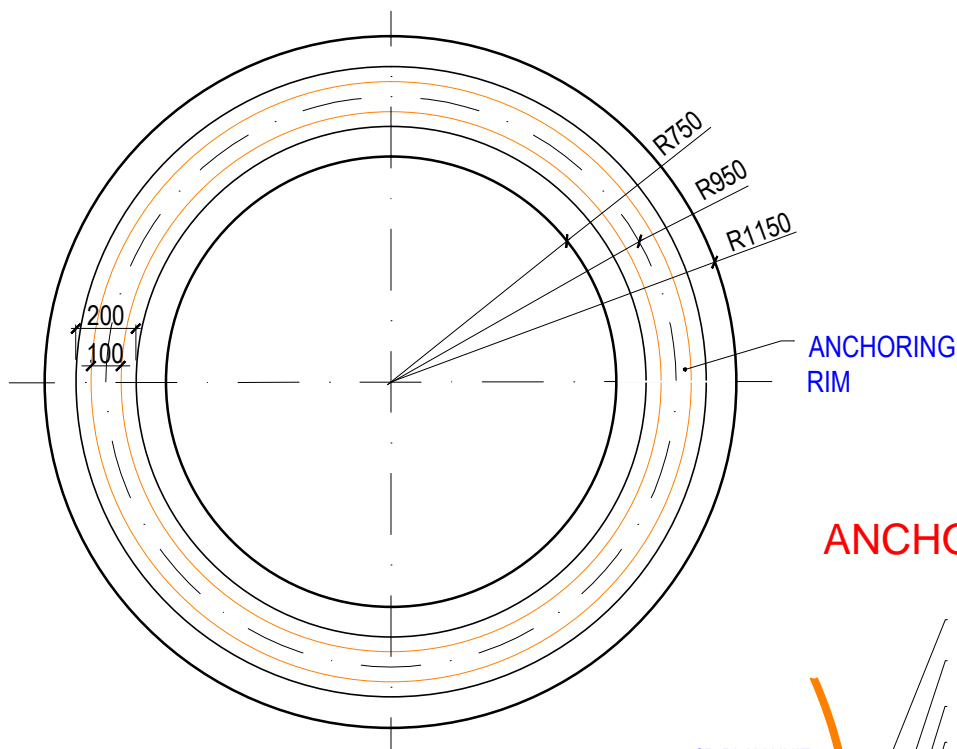

ANCHORING DETAIL (1:10)

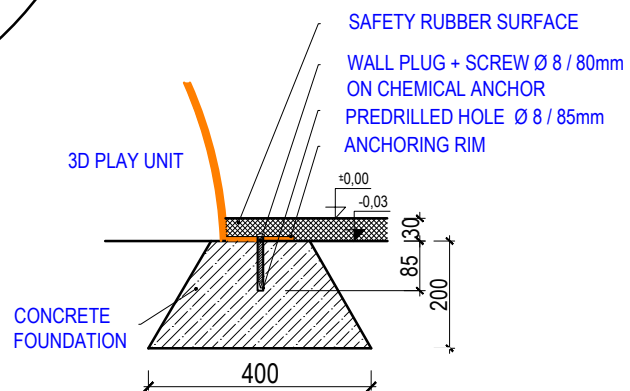

Author:

MgA. Maxmilián Blšták

3D PROGRAM, s.r.o.

Objízdná 1911
765 02 Otrokovice

Tel: 602 500 045

Email: info@3dprogram.eu



TECHNICAL DRAWING

Certified according to EN71 , EN1176

Date of issue 22.2.2021

E06 - BUMP

M 1:25, 1:10

format 1xA4

Foundation and anchoring - ground plan and section

E06_EN.dwg

revision 0